

Part 1 Foundation and framing

Two-level

Craftsman storage shed

Engineered for simplicity—do-it-yourself trusses and complete framing plans.



Who says a yard shed can't be beautiful? This shed

would grace any yard because it's well designed and built to last. The foundation is concrete, and the 2x4 walls are skinned with 1/2-in. plywood followed by cedar siding. And the roof is factory-painted steel screwed to heavy-duty trusses that you make yourself.

This solid shed has a 10 x 10-ft. lower storage area, and nearly 17 x 4 ft. of storage in the attic. This long, narrow space above is great for storing an extension ladder, planks, a kayak, a canoe—or all the above!

I'm not gonna sugarcoat this and tell you it'll only take a week to build. It's obvious from the details that this backyard project can take four to five full weeks of work. But when you're finished, you'll have something to be proud of.

You can easily break the project down into manageable steps and pick up where you left off at a later

date. In fact, we've divided this article into two parts

This article covers setting the forms, pouring the slab, and building the basic wall and roof framing. These framing techniques apply to any wood framing project, even a big project like building a garage or an addition. We'll walk you through the step-by-step framing process, plus the drawings will give you accurate measurements to use as a cutting guide.

If you've built a deck before, you can tackle this job. Beyond basic carpentry tools like a circular saw, level, tape measure, drill and screw gun, you'll need some concrete finishing tools and 8-ft. and 10-ft. stepladders. A pneumatic stapler is a great help but not essential.

A grand project like this is naturally going to cost more than a shed kit available at home centers. You'll spend about \$460 for concrete and forms plus \$3,500 for materials, including the metal roofing.



What you get:

- 10 x 10-ft. lower-level storage
- Spacious 4 x 17-ft. attic storage
- Wide double-door access
- Covered porch workspace
- Low-maintenance finish
- Bright interior
- Steel brackets for no-split fastening



Pour your slab on a level site



1 REMOVE all vegetation within 6 in. of the slab site. Roughly level the soil and dig the perimeter to a 7-in. depth (Fig. A). Set the 2x8 forms straight, square and level with 1x3 stakes. Coat the inside surface of the forms with vegetable oil so they'll be easier to remove. Lay two levels of No. 4 rebar around the perimeter (Fig. A).



2 POUR the concrete and screed it level with the forms. Be sure to have your anchor bolts and post brackets ready to set into the fresh concrete. Mark the locations on your forms. After the anchor bolts and post bases are positioned, finish the surface with a steel trowel. Cover the concrete with plastic for three days.

Our site sloped 5 in. from front to back. If yours slopes more than that, you may need to do some excavating and grading.

Remove the turf from the site (this is a must) plus at least 6 in. around the perimeter to allow for fastening the forms. Use 2x8 forms and screw them into 1x3 stakes that you can buy at a lumberyard.

Start by cutting the forms to length, then set them along one side and square the other sides to it. Drive a support stake 10 in. into the ground about every 4 ft. and near every corner. Measure the diagonals of the forms to check squareness and use a 4-ft. level to ensure that the forms are perfectly level. Cut off all the stakes even with the tops of the forms. This fussing over maintaining square and level is important: If your foundation is off, you'll fight a host of problems all the way to the roof. See **Fig. A** for slab details.

Calculate the volume of concrete you'll need and order an extra 1/4 cu. yd. for insurance. For our 10 x 18-ft. slab, we ordered 3 cu. yds. of concrete two days ahead of time. Be sure you've got at least two strong people to help when the concrete

arrives. If it looks like rain that morning, call and cancel the concrete delivery, then reschedule.

If possible, pick a clear 75-degree day to pour the concrete. The slab will turn out better if it's not too hot, and you won't wear yourself out from heat exposure. Wear eye protection, gloves and boots. Concrete can burn your skin with too much contact, so rinse your skin with water immediately if it splashes on you.

Before you pour, lay No. 4 rebar (Photo 1) around the perimeter of the slab to reinforce the edges. Lift the rebar to center it in the slab. Set your anchor bolts and the post anchors nearby so you won't forget to push them into the wet concrete. For more details on pouring and finishing concrete, see "Building a Concrete Pad," July/Aug. '96, p. 80, or "Pour a Concrete Sidewalk," May '00, p. 96. (To order copies, see p. 108.)

Note: If concrete work is not your idea of fun, you can have a pro do the job for you, but expect to pay about \$1,400. If you do it yourself, you'll only have to pay about \$375 for the concrete plus \$85 for rebar, anchor bolts and forms.

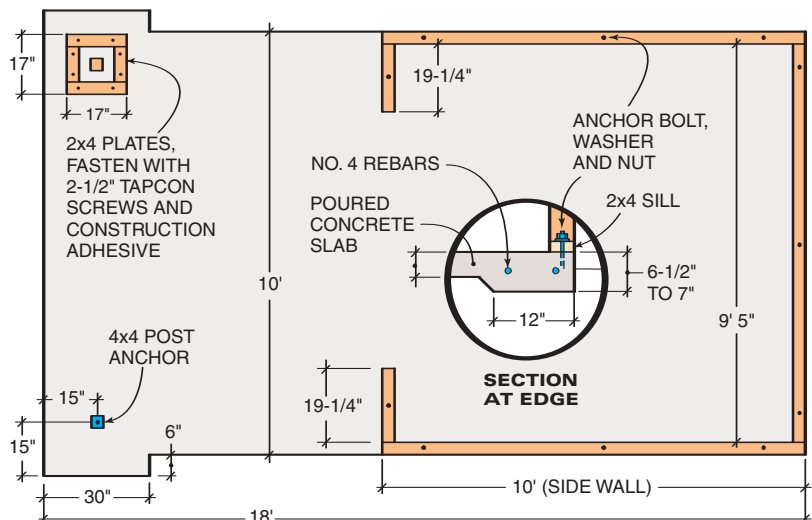
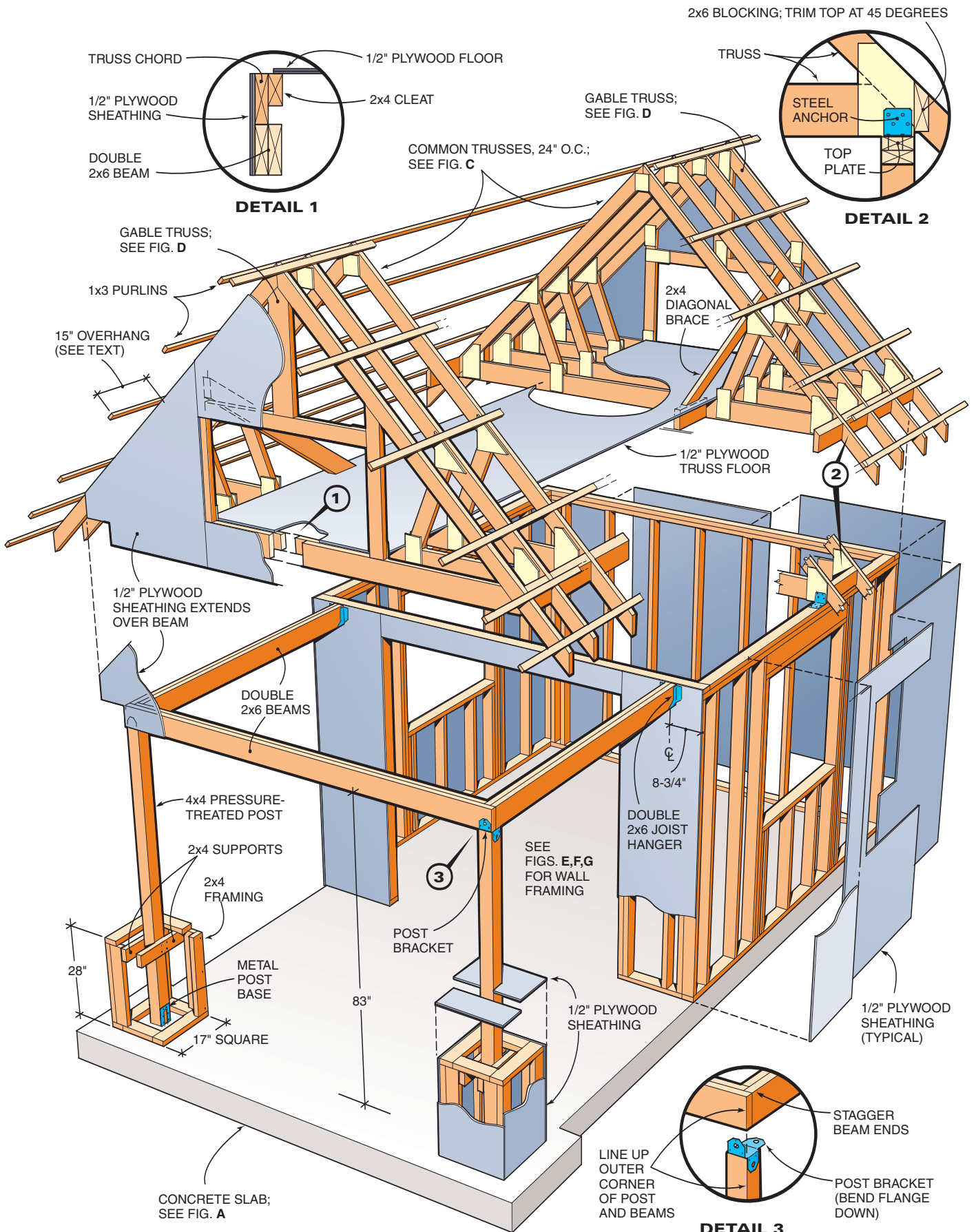

FIG. A SLAB LAYOUT

FIG. B FRAMING/SHEATHING

Craftsman Storage Shed



Build strong roof trusses

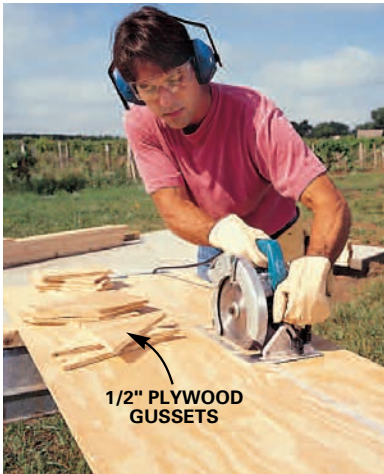

3 **RIP** strips from 1/2-in. CDX plywood to make the gussets for the trusses. Cut them into the shapes shown in Figs. C and D. Also cut the members for the first common truss.

Once the slab has cured for a couple of days, you'll be champing at the bit to get the walls built. Resist the urge and build the trusses first while you've got a clean, flat slab as a workspace. Study Figs. C and D for the truss dimensions and refer to the Materials List on p. 37 for the materials you'll need. Don't build the trusses on a surface that isn't flat; irregularities can throw off the trusses just enough to cause headaches later. Follow Photos 3 - 5 for instructions.

Note: Rent a 1/2-in. crown pneumatic stapler to fasten the gussets to the trusses, and rent a 1/4-in. crown stapler to fasten the gable shingles. Use a minimum of six staples per gusset (and don't forget the construction adhesive). The pneumatic stapler will really speed up the process. You'll probably save a few hours on this phase of the project. If you choose to hand-nail the gussets, use 6d common nails (eight nails per gusset).

Establish a front and back side for

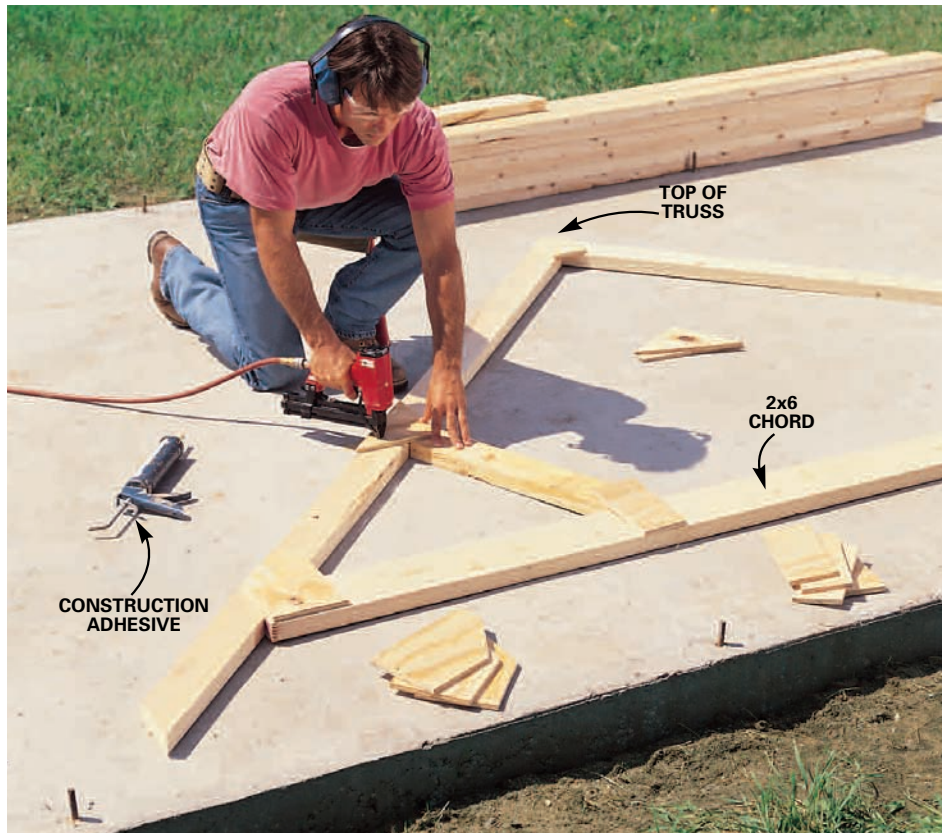

4 **GLUE** and staple the gussets to the common truss members using construction adhesive and a pneumatic stapler loaded with 1-1/8 in. staples. Once you've finished stapling the gussets to one side, flip the truss and attach the gussets to the other side. When this truss is completed, mark one side "front" and the other "back" to maintain consistency in the trusses. Note: The two gable end trusses (Fig. D) have gussets on the inner sides only. Measure the struts of this truss and cut the same length for the other trusses.

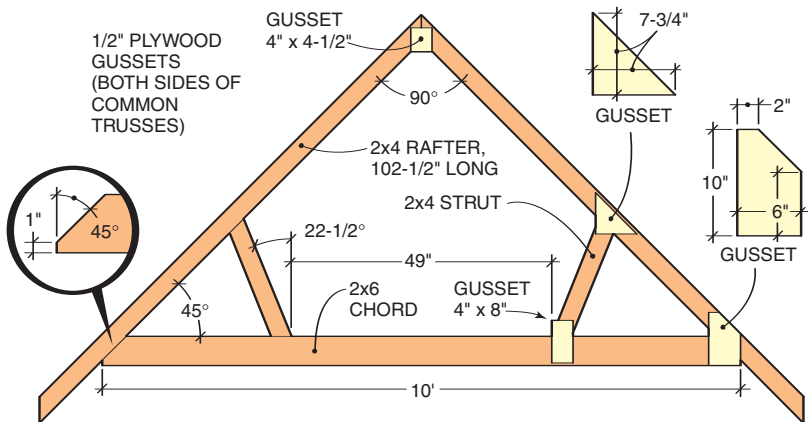

FIG. C COMMON TRUSS

Craftsman Storage Shed

Materials List

ITEM	QTY.
Trusses:	
1/2-in. CDX plywood	1 sheet
2x4 x 10' spf (spruce, pine or fir)	40
2x6 x 10' spf	15
Purlins:	
1x3 x 10' spf	12
1x3 x 8' spf	12
Walls, beams, posts and plates:	
2x4 x 7' spf	38
2x4 x 8' spf	4
4x4 x 14' spf	1
2x6 x 10' spf	1
2x6 x 7' spf	1
2x4 x 10' treated	4
2x4 x 10' spf	4
Wall sheathing and loft floor:	
1/2-in. CDX plywood	15
Brackets and fly rafters:	
4x4 x 10' cedar	2
2x8 x 10' cedar	4
1x2 x 10' cedar	4
Roofing:	
3-ft. wide x 102" steel roof panels	14
10-ft. 12/12 pitch steel roof caps	2
Roofing panels can be ordered at most home centers.	
Siding:	
No. 2 cedar shingles for gable ends	4 bundles
1/2" x 5-1/2" cedar siding (4-1/2" exposure)	800 ln. ft.
15-lb. and 30-lb. roofing felt	1 roll of each
Trim (corners, windows and doors, gables):	
2x6 x 10' cedar	2
2x8 x 12' cedar	2
1x4 x 10' cedar	7
1x8 x 8' (beam wraps and ceiling)	5
5/4 x 6 x 8' cedar (ripped for door and window trim)	18
2x4 x 8' cedar windowsill	1
Windows:	
1x6 x 8' cedar window jamb and stop	6
22" x 41-1/4" window barn sash	6
Doors:	
36" solid-core birch exterior doors	2
22" x 29" window barn sash	2
1/2" x 5-1/2" x 8' cedar door facing	2
1/2" x 5-1/2" x 7' cedar door facing	6
1x6 x 7' pine door jambs	3
Pine shims	4 pkgs.
Front posts (except 4x4s):	
1x12 x 10' cedar tapered post wrap	4
1x3 x 8' cedar post trim	2
2x8 x 10' cedar base caps (miter to fit)	2
2x4 x 10' cedar column capitals	1
2x4 x 10' treated column base framing	1
2x4 x 7' spf framing for column bases	5
1/2" exterior treated plywood	2
Wire stucco mesh	30 sq. ft.
Roofing felt (see siding)	
Cultured stone column façade	30 sq. ft.
Dry mortar mix (60-lb. bag)	2

Materials List continued on p. 50

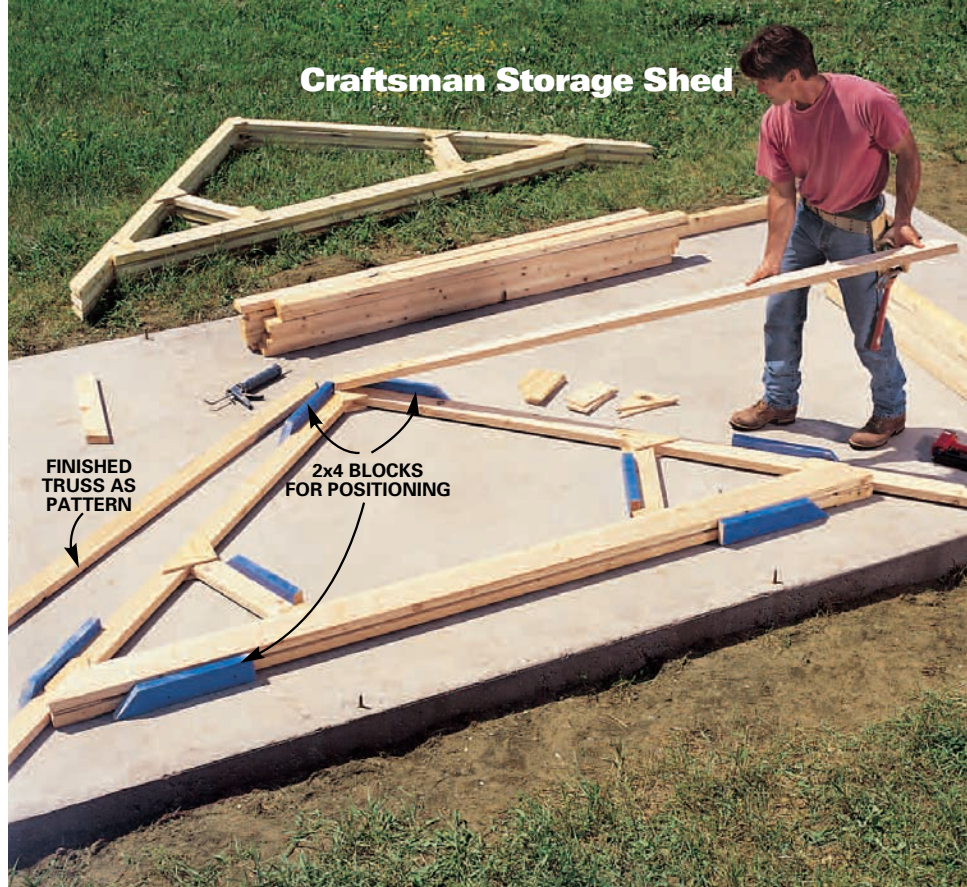

5 USE your first truss as the "pattern truss" for the other common and gable end trusses. Screw 2x4 blocks to the pattern truss as shown, then lay each truss piece over the pattern truss to ensure they're all a uniform size and shape. Remember: Mark front and back sides for each truss to maintain consistency. Assemble all the trusses and stack them flat and away from the slab.

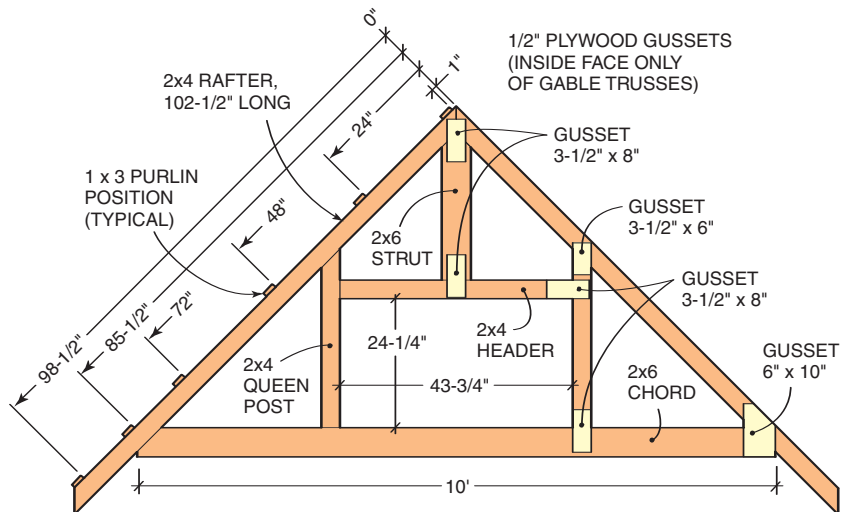

FIG. D GABLE TRUSS

each truss when you use the pattern method described in **Photo 5**. This will ensure that your trusses are uniform along the whole structure and that your metal roof won't kink because of dips from one truss to

the next. After the trusses are built, find a spot away from the slab to set them flat while you build the walls.



6 SNAP lines onto your slab 3-1/2 in. in from the edge of the slab to establish the layout for the walls. Cut the pressure-treated sole plates for the 2x4 wall assemblies, then set them inside the line and measure the anchor bolt distance as shown.



7 TRANSFER the measurement for the bolt location onto the topside of the sole plates. Drill 1/2-in. diameter holes with a spade bit so the bolts will slide through easily after the wall is built and positioned. Tip: Set a block under the plate to prevent your drill bit from hitting the slab as you penetrate the other side.

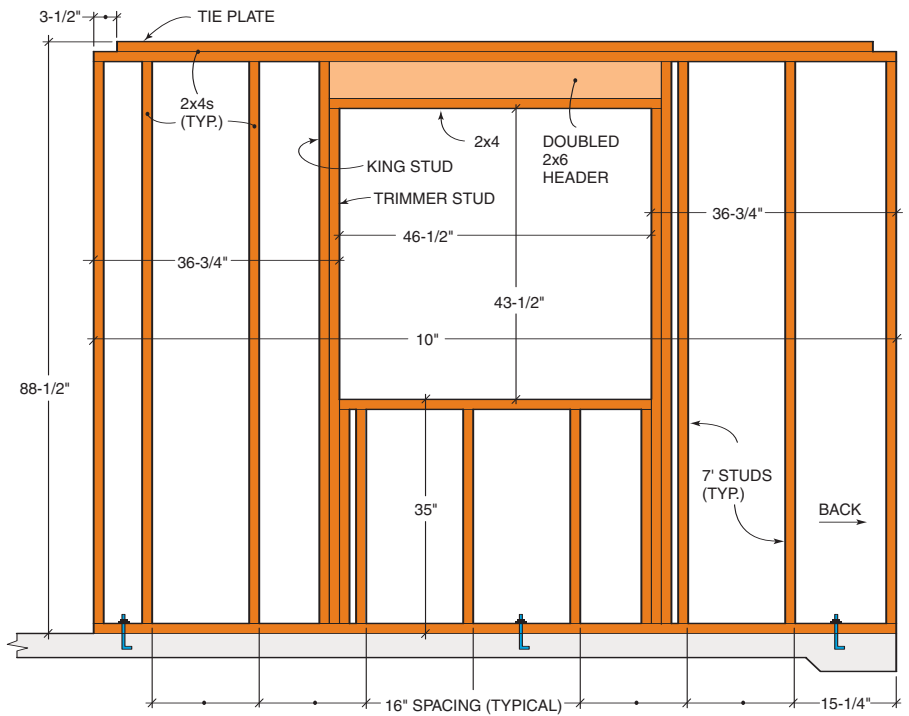

FIG. E SIDE WALL

Frame the walls and tip them up

It's best to snap lines on the slab that correspond to the inside edges of each wall, then cut your sole (bottom) plate and your top plate from 10-ft. 2x4s. To use the chalk line, just measure in 3-1/2 in. from the edge of the slab near the end of each wall section, pull a chalk line tight over your marks and snap it. You'll appreciate the lines because they'll help you accurately position the walls, even if you have a straight slab.

Follow the steps in **Photos 6 and 7** for drilling holes in the sole plate for the anchor bolts. Sometimes you'll find that an anchor bolt falls right under a stud location. If this happens, you can move the stud off the layout as long as it doesn't affect window or door placement. If it does, simply cut off the anchor bolt flush with the slab and install a drive-in-type concrete anchor after the wall is positioned.

Line up the top and bottom plates to mark your stud locations along with door and window header

openings. Marking both plates at the same time will make layout mistakes less likely. Follow the wall dimensions in **Figs. E, F and G**. Build the back wall first and tip it up and brace it while you frame the side

More CRAFTSMAN SHED >>>

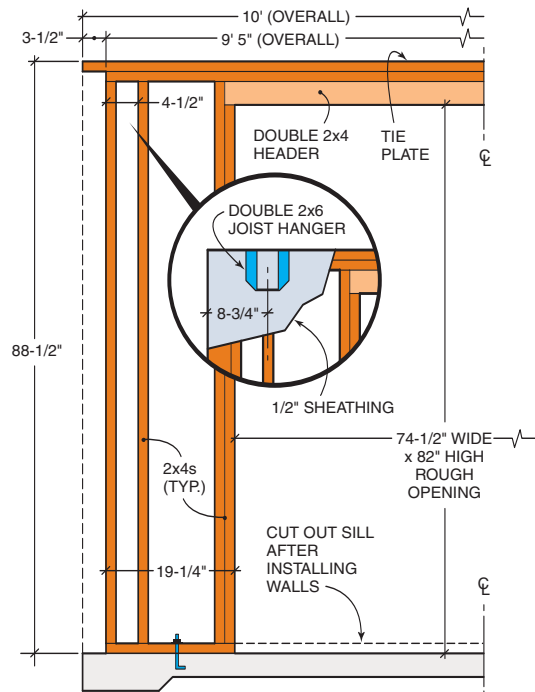

FIG. F FRONT WALL



8 **NAIL** each 2x4 wall assembly together using two 16d cement-coated nails at each connection. Nail the studs to the sole plate and the top plate. Do not nail the tie plates (2x4s above the top plate) to the top plates at this time. See Fig. E for window opening details to make your header and trimmers and cripple studs. Note that the side walls fit against the back wall.



9 **TIP** the walls up and drop them over the concrete anchors. Start with the back wall first. Temporarily brace the walls to keep them from falling in the wind, and tack the corners together with 16d nails. Don't drive the nails home until the plates are fastened and you're sure the top plates line up. Hammer the top plate from above if the tops of the walls aren't flush.

Lay out and build each wall section

walls. The stud spacing is measured specifically to accommodate 4- or 8-ft. wide sheathing plywood so the seams will always land on a stud.

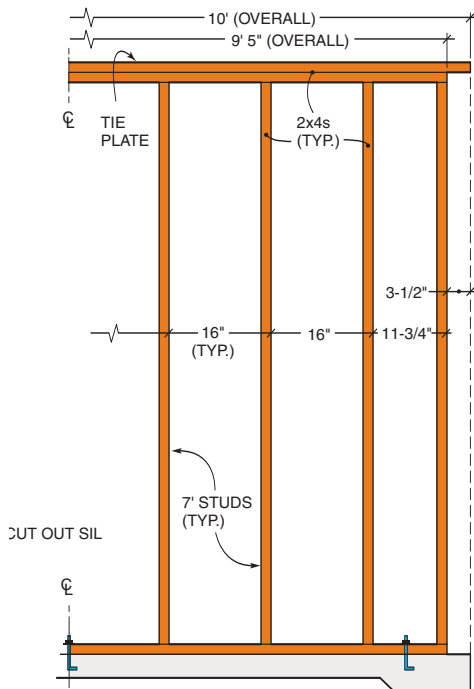

FIG. G BACK WALL

Make the window headers from two lengths of 2x6. Cut and nail (use 16d sinker nails) these pieces together, then drop them between the king studs. Nail them to the king studs and the top plate. Next nail the trimmer stud to the king stud and then install the sill and the cripple studs (**Photo 8**) below the sill. After you've framed the walls, tip them up into position (**Photo 9**), brace them, then fasten the sole plates to the anchor bolts.

Before you nail the wall corners together, climb up your stepladder and hammer along the top plate above the stud locations. This is necessary because the studs can work loose a bit from moving the walls and tipping them into position. Hammering down on the top plate will close any gaps so that the walls end up all the same height before you nail the corners together.



10 **MAKE SURE** the walls line up with the chalk lines you snapped earlier on your slab. Tighten the nuts on the anchor bolts. Align the corners and nail the wall sections together with 16d nails.

Tie the walls together, then plumb the corners



11 **NAIL** the tie plates to the top plates of each wall near each stud location. Drive two nails over each corner to lock the walls together.

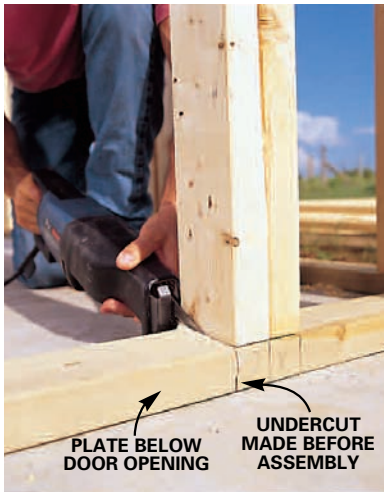

12 **CUT OUT** the bottom plate (your toes will appreciate this) for the doorway once the walls are secured to the slab. Note the undercut on the sole plate made before the wall was nailed together. This cut saves on saw blades!



13 **NAIL** diagonal braces across the wall once you've got each corner perfectly plumb (a helper is a must). Nail the brace at the sole plate, top plate and near the center of the wall. Nail 1/2-in. plywood sheathing to the front walls with 8d nails to brace them.

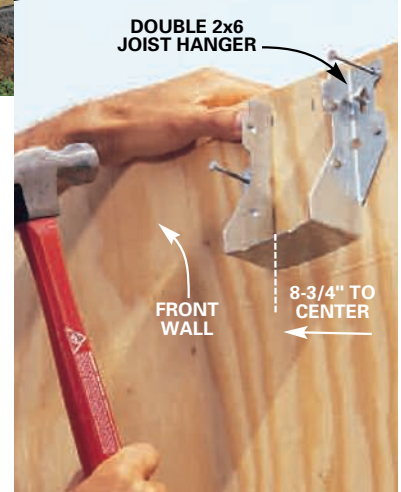

14 **NAIL** the double joist hangers to the front wall on each side so the top of the 2x6 beam will be flush with the top of the tie plate (Fig. B). Add another stud to the backside of the plywood if necessary to catch the joist hanger nails.

Cut tie plates from 2x4s and nail them (with 16d sinkers) to the top plate near the stud locations. Don't use tie plate material shorter than 3 ft.

Add braces (Photo 13) to the walls as you plumb the corners. The braces are necessary to keep the walls straight and solid while you install the trusses and nail the sheathing to the studs. Nail the braces from sole plate to top plate and into the studs. Then use a 4-ft. level to check the walls for plumb. Check both ends of a wall and split the difference to give the best

possible corners. It's unlikely that all wall corners will be perfect. You may have to compromise and get each corner "nearly perfect."

Set the front posts and beams square to the main shed

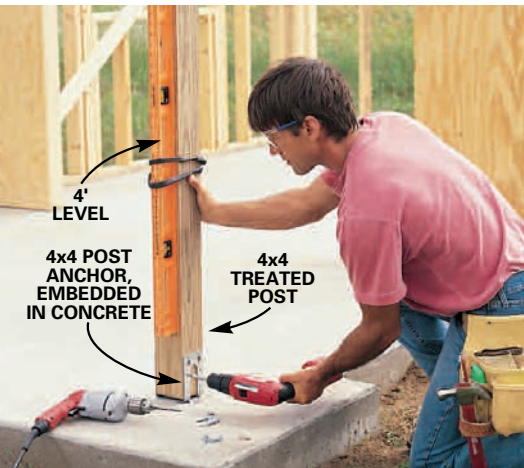

15 **SCREW** the 4x4 posts to the steel anchors using special screws designed for steel connectors. Be sure the post is close to plumb as you drive the screws.

Once you've got the front wall sheathed with plywood (Photo 13), measure from the outside corner and then down from the tie plate on each side to mark the position for the double joist hanger (Photo 14). These hangers will cradle the side beams and connect them to the main structure. (The side beams *are* structural.) Because the nailing pattern of joist hangers varies by brand, you may need to add another wall stud to be sure your nails hit solid wood. Lay the extra stud flat behind the plywood and nail it to the plates.

Next set the front posts into the anchors you installed when you poured the slab. Use special Simpson Strong-Drive steel fastener screws plus two 1/4 x 1-1/2 in. lag screws per post. If your anchor is slightly off position, you can slide the post forward or back to compensate. Just make sure the base position of each 4x4 post is exactly the same distance from the front wall. **Note:** Cut the top of the 4x4 posts 5-1/2 in. shorter than the wall height.



16 **NAIL** together the 2x6s that make each beam. Use a pair of 16d nails every 16 in. Set the two side beams first, then tack them to the joist hangers. Fasten them to the front posts. Notice how the beams interlock in the inset. Nail each end of the front beam into the side beams with three 16d nails. Each steel anchor for the top post and beam must have one side flange bent down to fasten under the beam.



17 **MARK** the truss layout on the top plates, starting at the back wall. Measure 16-in. centers. Tip up the rear gable end truss first, making sure it's centered on the wall. Use temporary braces nailed to the wall framing to help support the truss until the roof framing is completed. Set the front gable truss as well using temporary supports.

Nail the beams in place as shown in Photo 16. Screw the beam-to-post anchors on top of each 4x4. Bend down the arm of the anchor to secure the beam to the post. The

beams should be flush with the outside edges of the posts. Plumb the posts and add a brace (Photo 18).

Craftsman Storage Shed

Set the trusses and anchor them



18 SET each common truss after you've set the gable end trusses. Tie a string tightly between the gable trusses (about an inch or more above them) as a centerline guide for setting the common trusses. Check the overhang of each truss against the side wall as well, to ensure consistency. Fasten the trusses to the top plates by using the steel brackets shown in the inset. Be sure to align the truss chords on your marks on the top plates. The trusses are placed 16 in. on center, measured from the far side of the back wall framing. Use a horizontal brace to fasten the trusses and maintain spacing near the top.

Mark the locations for the trusses onto each tie plate and double side beam. Start at the back wall on each side wall; place the first mark at 15-1/4 in. and the rest every 16 in. all the way to the front. Get help to lift the trusses onto the top plates. Start with the gable trusses. Make sure the gable end trusses are positioned so the gussets face the inside of the structure. Nail temporary braces to the back wall and the front beams and posts to hold the gable end trusses in position as you fasten them to the tie plate. Use special steel anchors (**Photo 18 inset**) to connect the trusses to the walls. Make sure the trusses are centered over the outer walls.

Once the gable end trusses are set, drive a 16d nail halfway into the top of each truss and tie a string tightly from one end to the other (**Photo 18**). Center each truss under the string and check the overhang distance from the wall on each side. Screw each truss chord to the tie plate (**Photo 18 inset**). Use a 1x3 board to support the trusses near the top and maintain the proper spacing there as well (**Photo 19**). Position this support 24 in. down from the top so it can be used as a purlin to later support the metal



19 SLIDE two sheets of 1/2-in. plywood onto the 2x6 chords before you set the trusses over the front porch section of the shed (see Fig. B for details). Fasten them permanently with 8d nails to make the storage floor once the trusses are positioned. To complete the floor, you'll need an additional partial sheet, which you can set in place later. Nail the plywood loft floor to the top of the chords with 8d common nails (see Fig. B, Detail 1, for exact spacing near the gable end windows).

Craftsman Storage Shed

Install the purlins and plywood

roofing. Before you set the last four trusses, lift two sheets of plywood over the chords to use later for the flooring of the storage loft.

Nail a 4-ft. cleat to the chord of each gable truss (**Fig. B, Detail 1**) to support the plywood floor on each end. The gable window frames will butt into the floor later as they are nailed to the opening of each gable truss (**Fig. B**). Nail the plywood to the chords and then crosscut a partial piece of plywood to complete the floor. **Note:** Nail an 8-ft. diagonal brace from each gable truss (**Photo 20 and Fig. B**) through the floor of the loft and into a block positioned between the truss chords. These braces are *necessary* to add rigidity to the roof.

Nail the rest of the purlins to trusses. The purlins that extend past the gables must overlap at least two trusses because they, along with the brackets you'll install later in Part 2, help support the fly rafters. Don't trim the purlins to length yet. Leave them long until you measure the steel roofing panels and see how they'll lay out.

Nail the plywood sheathing to the walls to give rigidity and strength to the building. Nail 1/2-in. plywood to the exterior of the gable trusses as well. Once all the plywood is nailed off, remove the 2x4 braces from the inside walls. Now the framing phase is complete.

In our next issue, we'll make window frames and doors and add trim, siding, roofing and faux stonework to complete the project.

21 **NAIL** the 1/2-in. plywood sheathing to the wood framing with 8d nails. Space the nails every 6 in. along the studs. Nail around the window opening and into the header as well.



20 **NAIL** the purlins to the tops of the trusses with 8d nails (see **Fig. C** for correct placement). The purlins will support the metal roof that gets screwed in place later. Let the purlins overhang the gables by about 18 in. and trim them to exact length later.



Picking up where we left off

In this second installment, we'll guide you through the process of transforming the plain framed box into a beautiful building that'll be the envy of the neighborhood. The details are found in our clear, easy-to-follow photos and plan drawings.

The roof is composed of factory-finished durable steel panels that will go on in a fraction of the time it takes to install ordinary shingles. You just screw the panels to the roof framework and you're done. Order the length you need from your supplier (check with a home center to special-order it). If you buy off-the-shelf steel panels, you can cut them yourself with a metal-cutting blade in your circular saw.

The windows and doors we chose lend an authentic charm, but you could buy preassembled windows and doors for a slightly different

look and shorten the labor time.

Our quaint-looking windows are ordinary barn sashes that you hinge in a simple-to-construct cedar frame. The doors are solid-core birch exterior flush doors (flat as a pancake) that you cut a window opening into. Then you glue and nail cedar strips to the exterior for an authentic frame-and-panel look.

The exterior walls are adorned with cedar lap siding below and cedar shingles on the gable. The trim boards for the corners, windows and doors, along with the porch detailing, are pieces you make from ordinary construction-grade cedar. You make all the trim from 2x8s, 2x6s, 5/4 x 6 decking (1-in. thick cedar boards with rounded edges) and 1x12 and 1x4 cedar.

While we can't show a photo for every detail, we do illustrate all the basic techniques you'll need. The technical drawings are complete and will help you analyze and follow each process.

Last issue we left off with nailing the 1/2-in. plywood over the studs to complete the sheathing. Before you install the trim, windows and siding, staple 15-lb. felt paper over the sheathing (use either a hand-squeeze type or a hammer tacker stapler). The felt acts as a moisture barrier in case water gets behind the siding. Start at the bottom and staple it to the plywood every 12 in., and overlap each course 1-1/2 in.



1 COVER the sheathing with 15-lb. building paper and fasten it with a hammer tacker before installing any trim. Then cut the corner boards to the dimensions shown in Fig. K and nail them in place with 8d galvanized casing nails.

Make your own window frames and trim

Making windows like these is simpler than it looks. Study **Figs. A and C** for the construction details. Nail the corners of the jambs together with 6d casing nails. Screw the no-mortise hinges (see Buyer's Guide, p. 86) to the side jambs of the window frames (top jamb for the gable end windows). Then screw the other flange of the hinge to the window sashes.

Rip some 3/4 x 3/4-in. pieces from

wider boards to make the window stop. Nail the stop from the inside of the window frame so it butts against the windows when you close them. You can buy sliding-

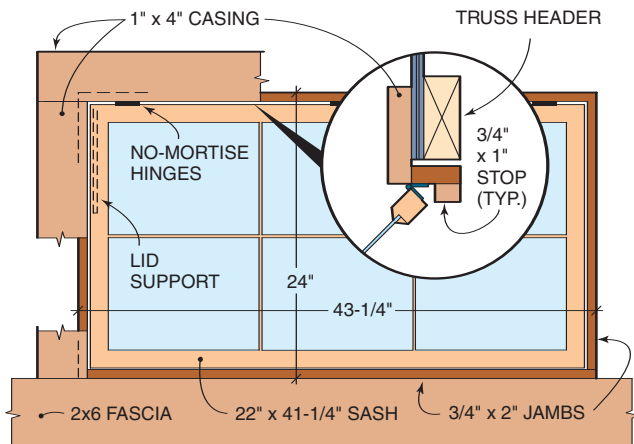
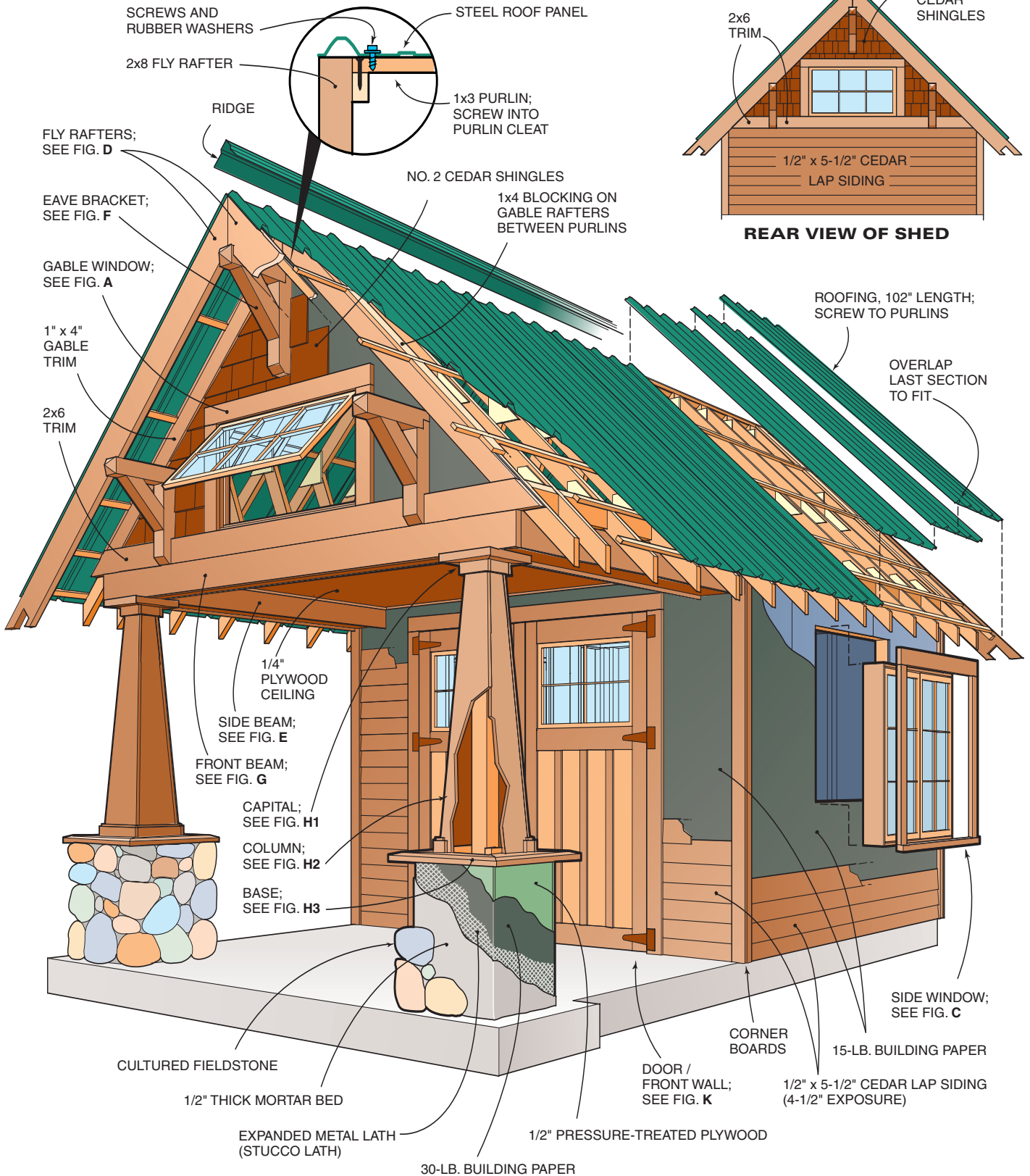

FIG. A GABLE WINDOW DETAIL

Craftsman Storage Shed

Oops! Last issue (Part I) the common trusses were incorrectly labeled 24" O.C. The correct spacing is 16" O.C.

FIG. B FINISH DETAILS



Building codes in some areas require additional seismic and high-wind anchors. Ask your local building inspector about local requirements.

Craftsman Storage Shed

bolt window latches and two pairs of locking arm lid supports to hold open the gable end windows.

Before you install the windows, rip the **corner trim boards** from 5/4 x 6 cedar decking (1-in. thick by 5-1/2 in. wide boards) to the dimensions in **Fig. K** and **Photo 1**. Note that one corner edge is wider and overlaps the other so the corner appears to be the same width from any angle. Nail the corner trim with 8d galvanized casing nails.



2 **NAIL** temporary blocks on the outside corners as shown. Preassemble your window frames and sashes (Figs. A and C) and then slide the window frame against the blocks from inside the shed. Shim all sides as necessary and nail the jambs to the framing with 8d galvanized nails.

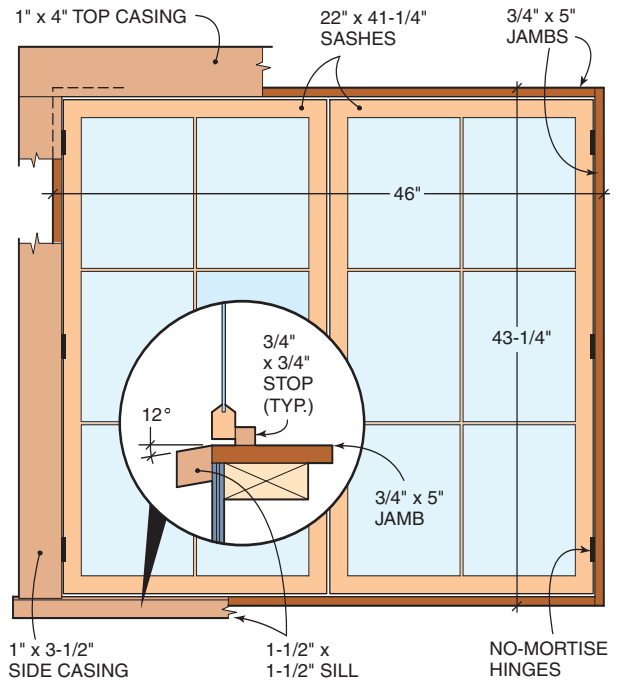

FIG. C SIDE WINDOW DETAIL

Window installation simplified

To make installing your window units easier, nail temporary blocks to the rough framing as shown in **Photo 2**. The blocks should be nailed across the corner so they trap the frame as you set it in place from the inside but still allow the window to open. Set the frame into the rough opening from the inside, push it against your blocks and check the sill for level. Shim as necessary. When the sill is level, check each side jamb of the frame for plumb (vertical). Shim and nail each side with 8d galvanized casing nails, then remove the temporary blocks. Cut the beveled sill piece as shown in **Fig. C**, and nail it to the frame and through the sheathing from the outside. Nail the side casings and the upper casing to the frame and sheathing as well. Repeat the process for the upper gable windows.

Build the door frame before installing the siding

The door frame is going to take more abuse than the window frames, so be sure to make it from 3/4-in. No. 2 pine instead of cedar. Examine **Fig. K** for the door construction details and special terms. With your door frame pieces (head jamb and side jambs) laid out on the floor, nail the side jambs to the

head jamb with 6d box nails. Tip the frame into the rough opening.

The next step is to check the head jamb for level with the side jambs resting on the slab. Have a friend help you with this. If the head jamb isn't level, you may have to trim the length of one side jamb slightly to level it. Next, shim the side jambs as

shown in **Photo 3**, making sure the jambs are flush with the exterior plywood. Shim and nail the sides and top so they're straight and solid. Drive a pair of nails every 2 ft. along the sides and top. Then nail the 5/4 casing (cut from 5/4 x 6 decking, which is approximately 1 in. thick) flush to the jambs and the framing.



3 CUT and assemble the door frame (Fig. K), then tape a 4-ft. level to a straight 2x6 to straighten and plumb each side of the door frame. Shim as necessary and use 10d galvanized casing nails to secure the jambs to the framing.



4 CUT AND NAIL the 5/4 x 4-in. casing (ripped from cedar decking) to the jamb and the sheathing with 8d casing nails. The casing is set flush with the jamb because the hinges are surface-mounted.

Siding tips

I've never met anyone who actually enjoys putting on lap siding (**Photo 5**), but I've met lots of people who love the job after it's done. Here are a few tips to make the task a bit easier:

- Mark the level of each course using a story pole. A **story pole** is any long piece of wood that you premark to show siding course intervals. Set the story pole

Tip

Windows and doors commonly have a metal flashing called a drip cap above the top piece of trim, nailed to the sheathing and then covered by siding. You won't need to flash these areas on this shed because of the large overhangs.

even with the slab and transfer these marks onto the corner, window and door trim. This method of marking off levels will save time and the hassle of constant measuring.

- Use only "splitless" siding nails. These special ribbed nails, available at home centers and lumberyards, minimize splitting. Even

they can split your siding when nailed within 3 in. of the end. To avoid this, drill a pilot hole first.

- Never finish a side with a skinny width of siding. Besides being fragile, narrow pieces tend to look out of place. When you get within

Craftsman Storage Shed

the last several courses, measure and adjust the row spacing as needed to avoid this problem.

- Minimize butt joints by avoiding short lengths of siding. Plan the lengths or try to specify what you need when you buy it. Most siding is now sold in random lengths. Separate the bundle into long and short lengths and plan ahead to minimize waste. Use the short pieces along windows and doors.

Tip Caulk all the joints where the siding meets the trim. Use a cedar-colored siliconized acrylic caulk.

5 MARK the siding courses on the corner and window trim with a story pole (see p.74). Nail the siding through the sheathing and into the studs with 8d siding nails after all the door and window trim is in place. Position each nail 3/4 in. up from the bottom edge and leave a 4-1/2 in. exposure on each course.



The beauty of the porch is in the details

Nail the 1/4-in. cedar plywood to the truss chords to create a porch ceiling. Use 1-1/4 in. wood-toned panel nails for the best results. Next make the wood boxes that attach to the outside of the double 2x6 beam (Fig. E). These boxes fill out the width of the beam (Photo 6) so the roof overhang is consistent with the rear section of the shed. Nail a 2x4 cleat to the 2x6 blocking you installed earlier between the trusses. Then nail the 1x8 trim (with the 3/4 x

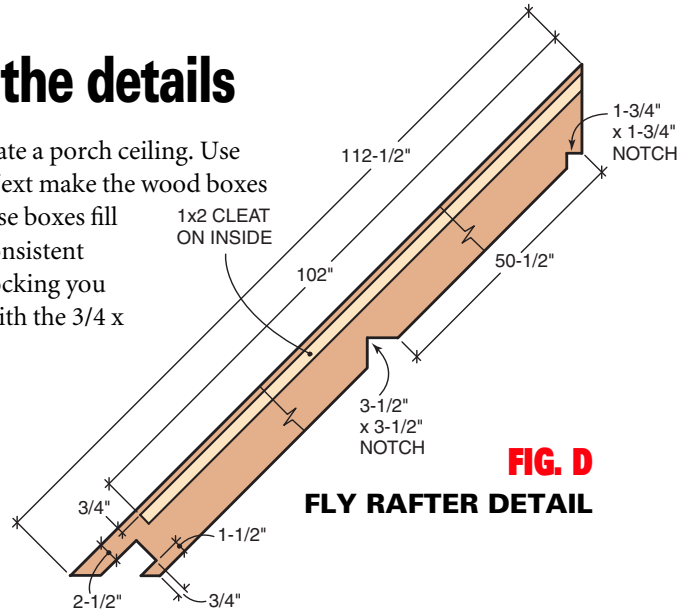

FIG. D
FLY RAFTER DETAIL

6 CUT 1/4-in. cedar plywood to fit the ceiling of the front porch and also to enclose the beams on each side. Note that the beams are widened to keep the extended rafter tails consistent with the sides of the shed (see Figs. E and G). Trim out the joint between the ceiling and beams with 3/4 x 1-in. cedar ripped from wider boards.

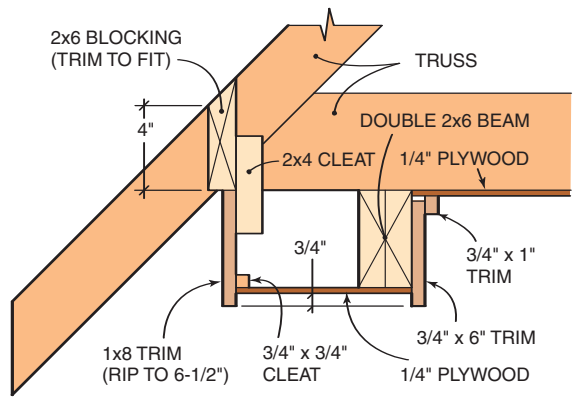

FIG. E SIDE BEAM DETAIL

You'll need help to set the brackets on the overhangs

3/4-in. cleat attached) to the 2x4 cleat you just nailed to the blocking. Remember, you're just widening the beam and putting 1/4-in. plywood under it as shown in **Photo 6**.

Next, trim the inside of the porch ceiling where it intersects with the

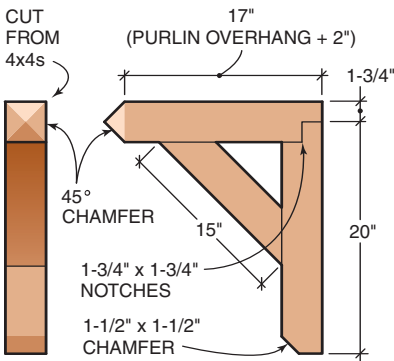

FIG. F EAVE BRACKET

Before installing our roof panels, we needed to build the overhang. Cut the fly rafter (**Figs. B and D**) to length and use a jigsaw to cut the notches and decorative ends. Also, glue and nail a cleat (**Fig. D**) 3/4 in. down from the top on each inner side. Trim the purlins to take the best advantage of the roofing panel widths (see p. 80). We trimmed ours at 15 in. from the gable sheathing. To prevent the purlins from splitting as you screw them to the fly rafter cleats (**Photo 7**), predrill pilot and countersink holes 3/8 in. from the end of each.

Make the front and rear gable brackets (**Fig. F**) from clear cedar 4x4. Cut the angled pieces with a power miter saw or a handsaw. Connect the top and back pieces of the bracket with 1/4 x 3-in. lag screws. Use 8d galvanized casing nails for each diagonal piece. Get a friend to help you install the brackets (**Photo 7**).

To further secure the brackets, cut a 2x6 for

each side and nail it to the trusses behind the brackets. Drill 5/16-in. pilot holes and secure the bracket with 3/8-in. x 4-1/2 in. lag screws.



8 NAIL on the remaining trim and then staple No. 2 cedar shingles to the gable ends with a pneumatic stapler. Start at the bottom with a double layer of shingles to accent the taper on the bottom against the horizontal trim board. Shoot at least two staples per shingle.

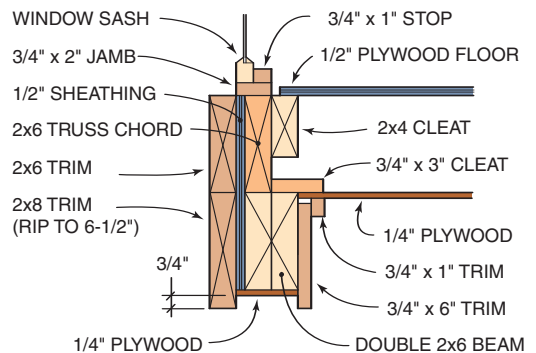

FIG. G FRONT BEAM DETAIL



7 TRIM the purlins to length for an ideal roofing layout (see text) then build the brackets to the dimensions shown in Fig. F. Screw the eave brackets to the gable sheathing with 3-in. screws from the backside of the sheathing after you slip them into the precut notches you cut in the fly rafter. Screw the purlins to the 1x2 cleat on the backside of the fly rafters before you install the brackets. The cleat is positioned 3/4 in. down from the top and follows the length of the fly rafter.

Craftsman Storage Shed

Roofing goes fast with precut panels

The 3-ft. wide roof panels are available at most home centers. Some home centers stock two or three basic colors. We chose a special-order green and also ordered it to the 102-in. length we needed to avoid having to cut it.

To get the panels to fit our shed

dimension from front to back, we had to half-lap the last panel. Half of the last panel covers half of the preceding panel. Also, to have a finished end on the long panel edge, we flipped it end for end.

Have a screw gun ready to drive the special rubber-washed fasten-

ers into the purlins. Don't step on the roof panels or you'll put a nasty crease in them. As you go, screw the panels off and install each 10-ft. long roof panel cap (**Fig. B**) to the roof panels. Set a ladder up on the gable side to reach, and get a screw in every 3 ft.

Tip

If you must cut this stuff, buy a Carborundum metal-cutting blade for your circular saw. Wear a face shield and hearing protection. Be sure the panels are well supported as you cut.

Tip

Before you cut your purlins to length to install the fly rafters, just lay the roofing panels out on your lawn and measure the coverage.



9 **SCREW** the steel roofing to the purlins (the horizontal wood strips) with special self-tapping screws with built-in rubber washers (**Fig. B**). Each roof panel is 102 in. long. Be sure to specify length when you order or you'll need to cut them. Wear leather gloves when you handle this stuff. The edges are sharp! Begin installing the steel roof cap when you're at the halfway point.

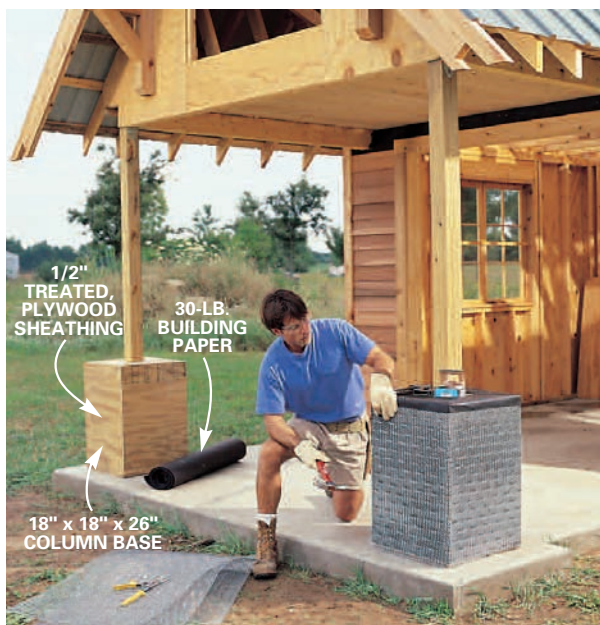

10 **FRAME AND SHEATHE** the column bases using treated plates and plywood. Screw the plates into the slab with concrete screws. Staple 30-lb. felt to the entire base. Lay expanded wire mesh over the felt and plywood. Nail the mesh every 6 in. with 1-1/4 in. roofing nails.

Fasten the gable shingles with an air-powered stapler

Have one person up on the ladder setting and stapling shingles and the other on the ground cutting. Cut and tack 15-lb. felt over the plywood sheathing, then nail all the window and gable trim in place as shown in **Fig. B**.

To get all the shingles even across the bottom of each course, cut a 6-in. length off a scrap shingle and mark it "gauge." Use this to measure each shingle exposure as you staple it in place. Drive at least two 1-1/8 in. long staples in each shingle so the next

course will hide your staples (**Photo 8**). Stagger the joints on each row of shingles to prevent leaks. The gable is a triangle; cut the angled pieces carefully on your miter saw or table saw.

Tapered columns complement the Craftsman styling

Frame the column bases as shown in Part 1 and nail 1/2-in. treated plywood to the base framing. Staple 30-lb. building paper to the plywood base (use a squeeze-type or hammer tacker with 1/4-in. staples). Next, nail the expanded metal lath (commonly referred to as stucco mesh) to the plywood. Metal lath is available at home centers and is a must for installing cultured stone (lightweight, cast concrete

that looks like real stone; see **Photo 13**). See p. 38 in this issue for more information on installing cast stone.

Study **Fig. H1** for construction details for the upper columns and capitals. Miter the 2x8 cap pieces and nail them to the top of the plywood base. Use 10d galvanized nails. Next rip some 2x4s to 3 in., then crosscut them into 9-in. lengths and screw them between the 4x4 post and the 2x8 base cap. These cleats will provide backing for the tapered column boards.

Now taper the 1x12s to the dimensions in **Fig. H2** with your circular saw. Note that the taper is the same on all the pieces, but one pair for each column is narrower by 1-1/2 in. Glue (use Titebond II) and nail three sides of the tapered column together before you set it in place. Position the assembly around the 4x4 post (Photo 11) and then glue and nail

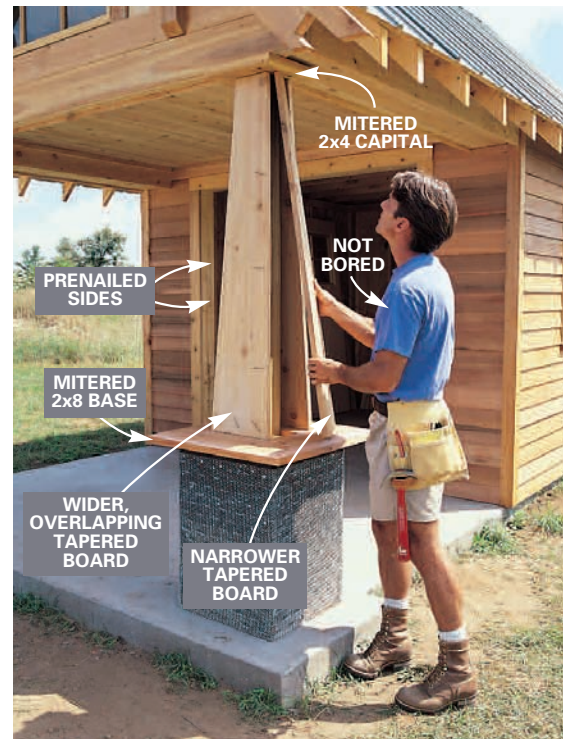

11 ASSEMBLE the base and capitals as shown in Figs. H1 – H3, then fit each tapered section of the front columns. Note that the front and backside boards of the columns are wider because they overlap the side boards. Once the column pieces are nailed together, secure them to the mitered base and capital on each side with 8d casing nails. Add the smaller trim around the top and bottom of the tapered columns to hide any gaps.

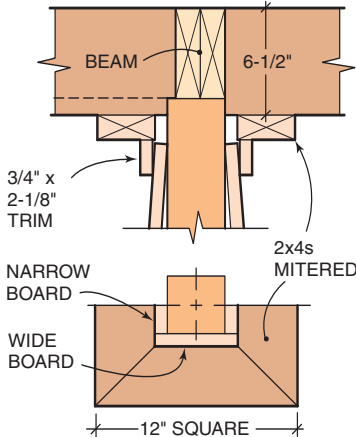

FIG. H1 CAPITAL DETAIL

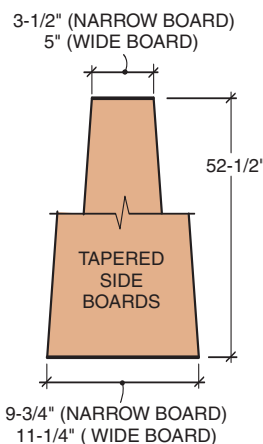

FIG. H2 COLUMN DETAIL

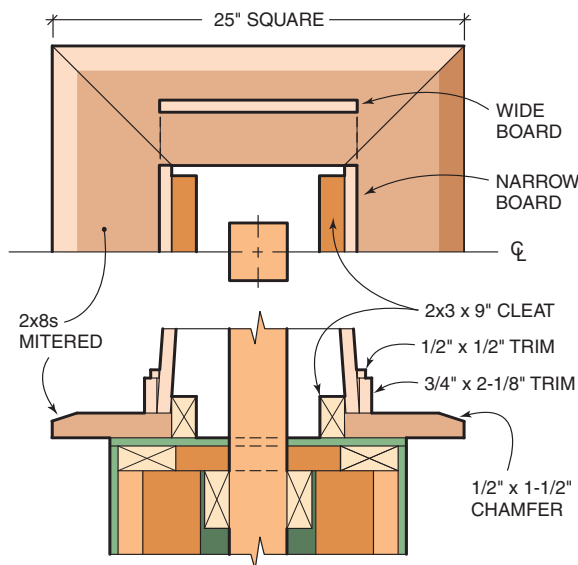

FIG. H3 BASE DETAIL

the last tapered board in place. Center the tapered assembly to the base and capital and nail it in place with 8d casing nails.

Cut the small pieces of trim for the base around the top and bottom of the tapered sections (**Figs. H1 and H3**) and nail them in place with No. 4 or smaller finish nails. Caulk the joints around the base to keep out rain.

Craftsman Storage Shed

Add cedar batters to door fronts for a paneled look

Think of these double doors as panels that you need to hang so the gaps are even around each door. If you've made your opening square and straight, you'll have an easier task ahead of you. Cut the opening in the door to match your window sash size, then apply the wood strips to the front side of the door. Have a full-service lumberyard plane some cedar boards to 1/2 in. thick (you may have to pay a small fee). Rip them to width and cut them to length. Adding the strips of wood over the doors is as simple as cutting them to the right size (**Fig. K**), applying beads of construction adhesive to the back of each strip, and then nailing each piece to the front side of the door. The strips around the window overlap the opening and act as stops for the front side.

Once the glue dries, set the window in from the backside and nail some stop strips (**Fig. J**) to the

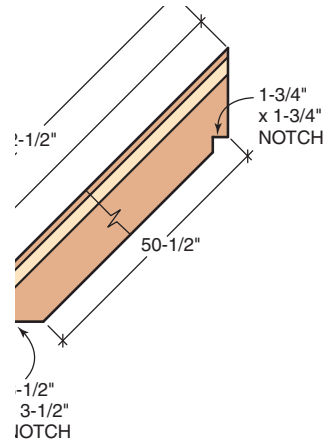

FIG. J HEAD JAMB

FLY RAFTER DETAIL

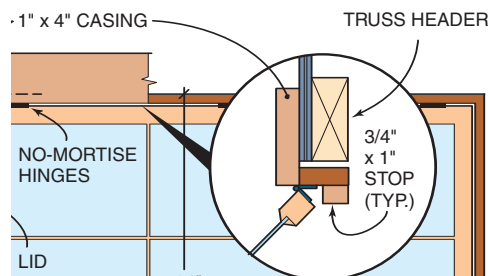

FIG. K FRONT WALL/DOOR DETAILS

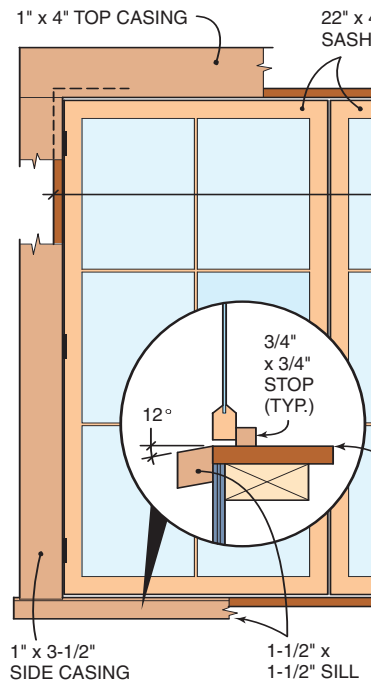

FIG. C SIDE WINDOW





12 **CUT** the window opening in each door with a circular saw and finish the corners with a jigsaw. Make the opening just large enough for the window. Glue 1/2-in. thick cedar board to the front surface of a solid-core birch exterior door to create a panel effect for each door. Fit the doors in the opening by shimming them temporarily. Position the hinges and drill pilot holes for the lag screws.

sides of the window opening to hold the window in place.

Trim the doors as necessary to fit the opening. Allow about a 1/8-in. gap on the sides and top, and a 1/4-in. total gap in the middle and bottom. Remember, the door fronts are flush with the door trim. Drive shims between the slab and the bottom of the doors to help you center them in the opening. Drill the holes for your hinges and prop the doors in the opening. Drive lag screws into the hinges and door as shown and then add the latch hardware. We painted our hardware a deep tan color to make it blend better with the wood.

Installing cultured stone is like setting thick tile

Mix your mortar to the consistency of mashed potatoes—not the lumpy ones your Aunt Doris makes but your mother-in-law’s smoothest creation. Work on a shady day if you can. It seems like every manufacturer has its own how-to recommendations, but the idea is to push mortar into the stucco mesh until it’s about 1/2 in. thick (read the instructions supplied by the manufacturer). Work an area several inches beyond each stone you choose to set. Have several stones ready to select from. Keep a bucket of water handy and dunk the stone before you apply mortar to it. Butter the back of a corner stone first (**Photo 13**) and push it into the mortar. Then grab the next stone and set it. Set all the lower corner pieces and then find stones to fill in between. Work your way all around the base about halfway up, then start on the next column and repeat the process to give the lower stones

time to set and dry in place. If the stones start to fall away, you may need to prop them with sticks or slow down and wait for the mortar to firm up. **Note:** You may have some gaps if you’re working with round stones. Use the smaller ones provided to fill the gaps. We even used a few real stones about 3 in. or so in diameter to help fill gaps. When you reach the top, you may have to do a little trimming with a hammer and chisel to get the stones to fit. We had good luck and were able to fit all but four.

After the stones are all set, you’ll need to add mortar between them. Get a grout bag from your stone supplier. Mix the mortar a bit thinner than before and scoop some into the bag. Squeeze the bag

and direct the mortar between stones. Once you’ve filled the gaps, go back and scrape away the excess with a striking tool. A masonry brush is handy to clean away excess mortar. Try not to get mortar everywhere. Be as neat as you can with the mortar and avoid getting it on the face of the stones. Follow the manufacturer’s instructions. 🏠



Finishing details

Apply a deck sealer to the exterior of your shed or paint it if you like. We used an oil finish called Behr NWF Waterproofing Wood Sealer that did not have a film residue. You’ll need to apply it again in about two years. Natural graying will occur eventually with exposure to the elements. You can always recapture the fresh-cut look of cedar later with a deck-and-siding cleaner. Enjoy!

13 **PUSH** a 1/2-in. thick mortar bed into the wire mesh. Butter the back of the cultured fieldstone pieces as you fit them to each column base. It’s best to start at the bottom and do only the lower half, then go to the next column base. After the lower half has dried and set, you can continue to set the stones for each upper half. Grout according to the manufacturer’s instructions.